



ETI Roller Barrier



Certificates

Country	Certificate	Class	Usage	Grade	Test Certificate No.
E.U (Europe)	CE Certificate	Crash Barrier (Length of Need)	Median, Road sides	H1, H2	No.1020-CPR-090-035829
E.U (Europe)	EN1317 Crash Test	Crash Barrier (Length of Need)	Median, Road sides	H1, H2	2016-3-0020-002
E.U (Europe)	CEN TS 1317 Crash Test	Crash Barrier (Motorcycle Protection System)	Median Road sides	CEN60	M075/M077
USA	FHWA Certificate	Eligibility	Median, Road sides		HSST-1/B-291
USA	MASH Crash Test	Crash Barrier (Length of Need)	Median, Road sides	TL3, TL4	MASH007~9
USA	MASH Crash Test	Crash Barrier (Transition)	Transition to Wbeam	TL3	TR-P39240-01-NC
KOREA	SB Crash Test	Crash Barrier (Length of Need)	Median, Road Sides	SB4, SB5	10-0936948

Project Reference

Country

KOREA, INDONESIA, THAILAND, VIETNAM, PHILIPPINES, MALAYSIA, TAIWAN, KAZAKHSTAN, PAKISTAN, TURKEY, MONGOLIA, AUSTRALIA, CURACAO, SAUDI ARABIA, CHINA, INDIA, SOUTH AFRICA, GHANA, ROMANIA, CHILE, MEXICO, GEORGIA PUERTORICO Etc.



Project Reference



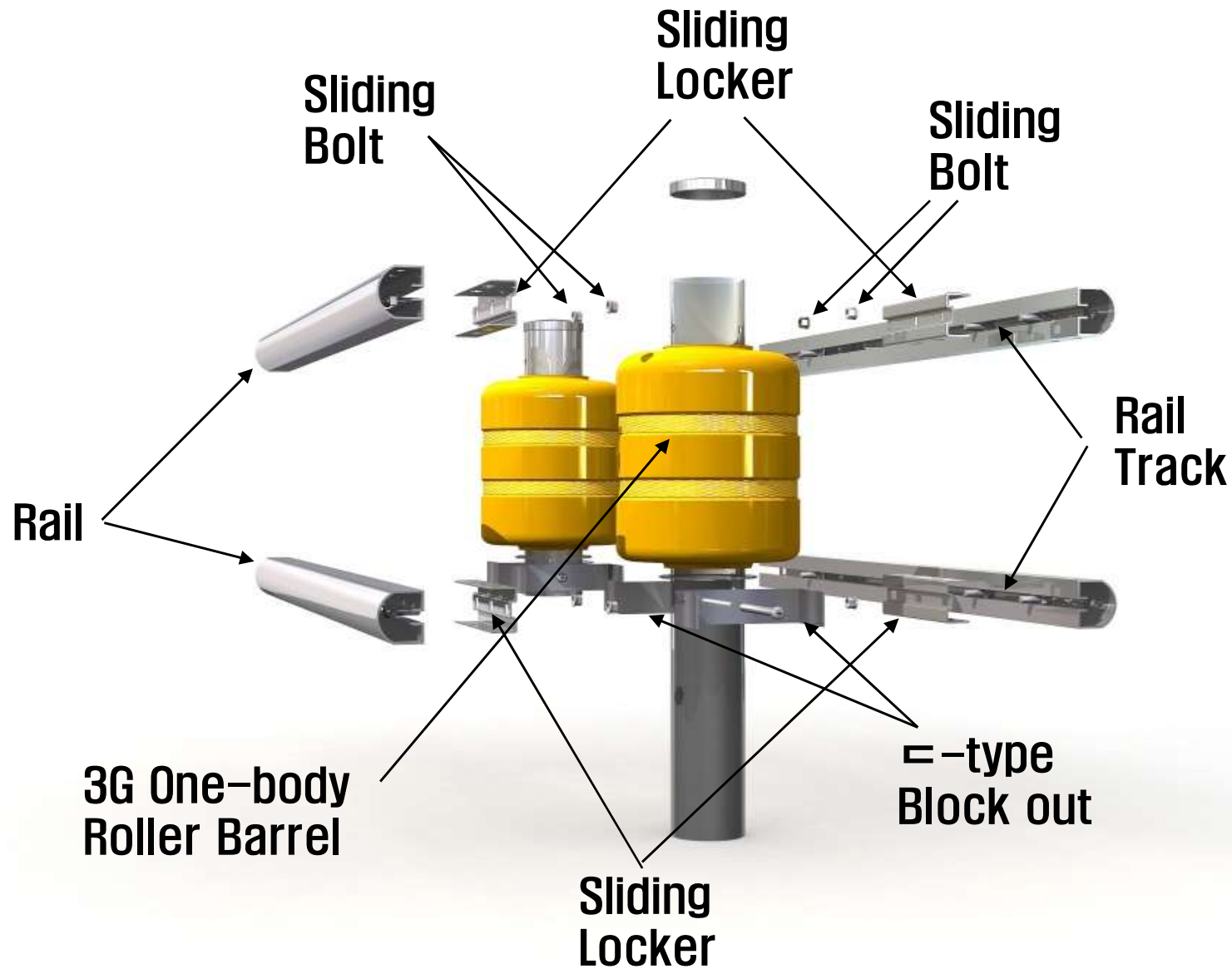

Product Aspect





Technical Competitiveness

No.	Technology	Effect
1	<p>International Patented “Rail Track Sliding Shock Absorbing Technology”</p> 	<p>–Maximize Shock Absorbing for Various Type of Vehicles</p>
2	<p>Accredited and Approved product.</p> 	<p>–USA LON (FHWA, MASH TL4) –USA Transition(TL3) –EUROPE (CE, EN1317 H2) –EUROPE (CEN MOTORBIKE PROTECTION CERT.)</p>

Technical Competitiveness

No.	Technology	Effect
3	<p>≡ -Type Block Out on Bottom Rail</p> 	<p>-Optimize Shock Absorbing for Various Type of Vehicles</p>
4	<p>Sliding Locker Inside Upper and Bottom Rail</p> 	<p>-Maximize Shock Absorbing by Roller, Post, Sliding</p>

Technical Competitiveness

No.	Technology	Effect
5	<p data-bbox="324 379 1377 438">Specially Designed Sliding Bolt Inside Rails</p> 	<p data-bbox="1451 384 1951 499">–Maximize Shock Absorbing by Sliding</p> <p data-bbox="1451 571 1921 686">–Tighten Locker, Blockout, Post, Rail</p>
6	<p data-bbox="309 903 1294 1018">Advanced 3rd Generation Injection cum Foaming Tech. (One–Body Roller Barrel)</p> 	<p data-bbox="1451 903 2056 1142">–High Density –Durable Shock Absorbing Performance –Sleek skin</p> <p data-bbox="1451 1166 1480 1187">–</p>

Factory Overview



Factory 1



Factory 2



Factory 3

Production Line



Roll Forming Machine (Rail)



High Frequency Bending Machine



Press Machine



Foaming Machine



Steel Tube Machine



Roll Forming Machine (Sound Barrier)



Super Big Injection Machine (Sound Barrier)



Full Automatic Injection and Cooling Machine

THANK YOU